

PANTS FINISHER PF 50-3D

The innovative achiever with unique 3D measurement technology



Pressing for Excellence

Digital and 3-dimensional measurement of trousers with the innovative Thullex measuring system.

Your benefits:

- ✓ **Reduces production costs:** Comprehensive measurement of trousers during finishing process
- ✓ **Maximum quality standard:** Consistent measurement data acquisition according to defined criteria
- ✓ **„Perfect Fit“:** Highest flexibility defining the measurement data and its acquisition
Besides waistband and leg length, there are endless possibilities of additional measuring points
- ✓ **VEIT Connectivity:** Industry 4.0 connection enables the exchange of process data with manufacturing and ERP systems

Digitize now.
Your step to Industry 4.0!



Digital measuring device

- Measurement of seat, waist and inseam dimensions during finishing process
- Efficient quality control:
Fast detection of production deviations
Data collection for quality assurance purposes
- Quality assurance through complete data acquisition

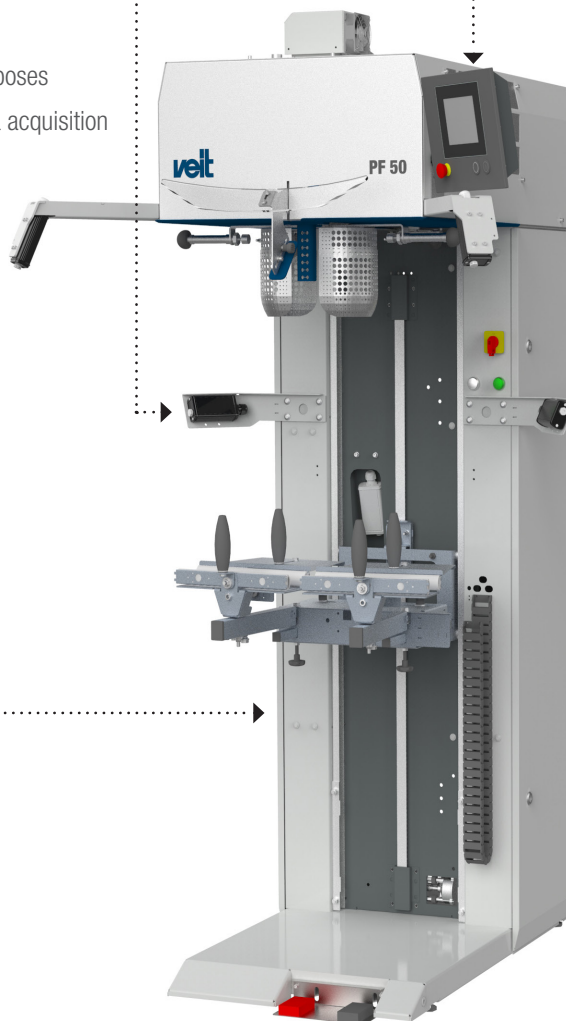

Control Panel

- Modern control technology
- New, intuitive operating concept
- Touch Screen: All program parameters can be viewed at a glance or changed in a moment
- Finish programs can be imported via barcode or RFID scanner

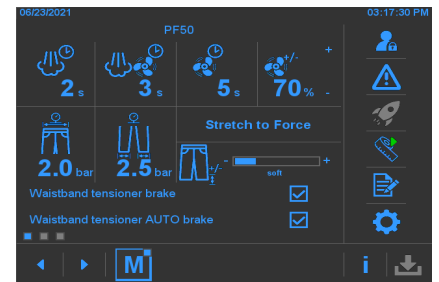

Technical data

- Dimensions: l x w x h (mm)
1080 x 1250 x 2140
- Electrical power supply:
Connection voltage 220-230 V / 50 Hz
220-240 V / 60 Hz
- Connected load 1.7 kW
(at standard setting)
- Steam supply:
Connection value 6 bar
Steam / condensate 1/2"
Steam consumption approx. 15 kg/h
- Compressed air connection: 5-8 bar

Factory Suite

- Database interfaces: RestAPI
- Individual measuring sections: specially definable measuring sections
- Real-time feedback at thresholds:
automated notifications

We are happy to advise you.

VEIT GmbH | Justus-von-Liebig-Straße 15 | 86899 Landsberg am Lech | Phone: +49 8191 479-100 | E-Mail: info@veit.de | www.veit.de