

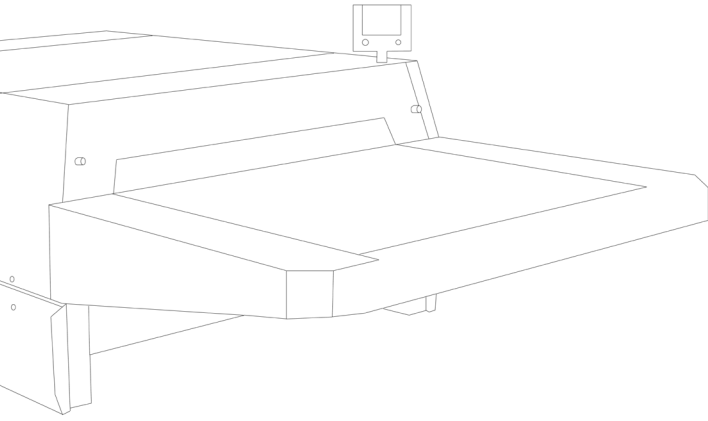

Pressing for Excellence



FUSING MACHINE FM

Design and ergonomics combined

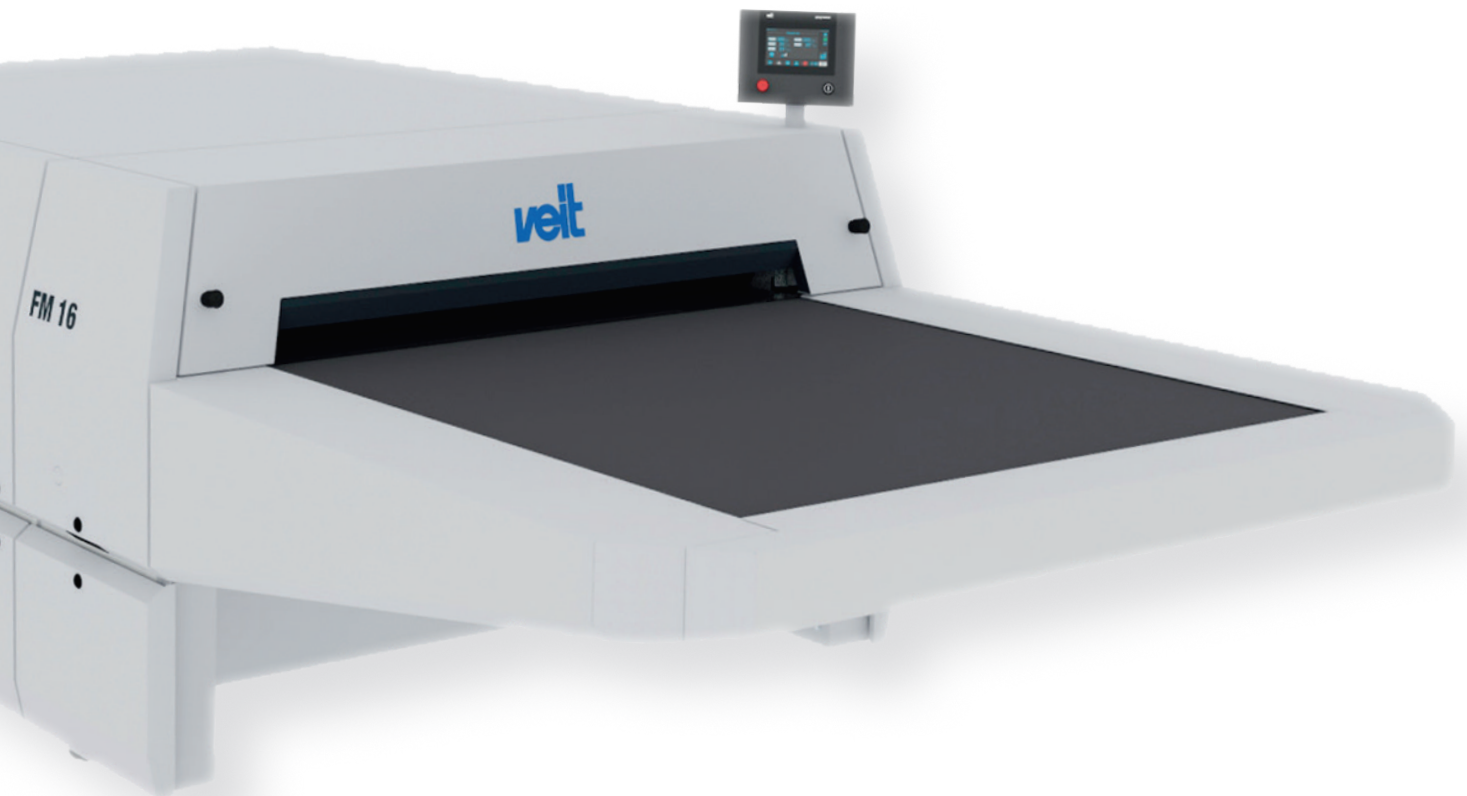





velt

velt

FM 16

FUSING MACHINE FM

Design meets ergonomics.

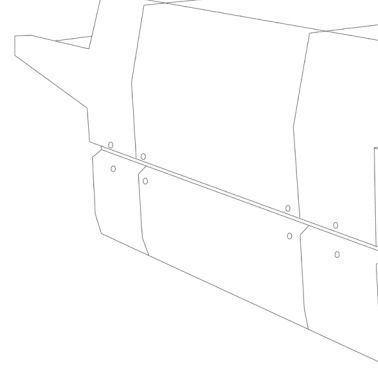

Visibility and accessibility

- › Improved access to smoothing device due to reduced machine width in the area of the cooling belt
- › Optimised viewing window for better visibility of the goods

Optimal fusing

thanks to exact temperature control directly at the belt

Optimal adjustment

of pressure system (soft, medium) and heating sequence (top, bottom) to the materials to be processed

Perfectly designed service concept

allows easy and regular cleaning of machine



Consistent fusing quality

due to optimized cleaning of the belts both on the inner and the outer side. Consequently, considerably less contamination of roller and fusing material

Lowest possible energy consumption due to:

- › Separate feeding belt, no cooling of transport belt outside of machine
- › Decoupling of heating zones from machine frame
- › Enclosure of the complete machine to avoid draughts and reduce heat loss

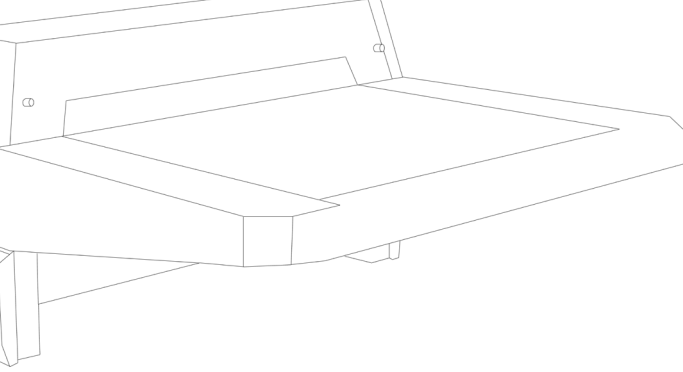

Consistent fusing results
due to consistent pressure over the entire operating width

Control

- › Capacitive touch display for easier operation
- › User-optimised user interface
- › Diagnostic and remote service capability
- › Rotatable and tiltable display

Functionality

- › Removable feeding element FE for uncomplicated installation in confined spaces
- › Start-stop function of the input belt in case of deviation from the set fusing parameters



Reduced wear and tear of belt
through contact-free belt control

Ergonomics

- › Weight savings on side panels for easier maintenance
- › Reduced basic machine height
- › Easy access to power supply
- › Reduced environmental temperature due to separate and cool input belt

The heating control system

Outstanding fusing results thanks to an extremely precise control of the two important fusing parameters – temperature and pressure

Modern high-tech interlinings often have only a rather small temperature range for optimal bonding with the glue. Consequently, exact temperature control today is far more important than ever before. To meet these requirements, VEIT has developed a new, innovative heating control system.

The new control element measures the temperature directly at the belt and therefore reacts extremely fast to any changes. The pre-set temperature can be maintained at a constant level and be precisely controlled. In combination with the tried-and-trusted VEIT heating units and the geometry of the heating zones, the adhesive's flow properties are perfectly set for further processing.

The Heating Element

For perfect heat radiation, stability over the entire width of the machine is essential. The heating element's aluminium construction absorbs only little energy, thus allowing best possible heat transfer to the fusing material.

Configuration of heating zones BOTTOM or TOP

Different applications require individual technical solutions. The design of the heating element when fusing outerwear parts will differ from the layout for an application in shirt fusing. Perfect adjustment of the heating zone is essential for successful fusing. VEIT's configurable heating zones are the answer to this challenge. This unique technology allows optimised adjustment of the fusing machine to the individual application.

Benefits

- › Even temperature transfer to the whole fusing area
- › Minimum loss of heat thanks to optimum heat control
- › Fast adjustment to changes in temperature with no loss of time
- › Exact temperature control without any significant deviations
- › Targeted heat transfer without loss of energy thanks to special insulation

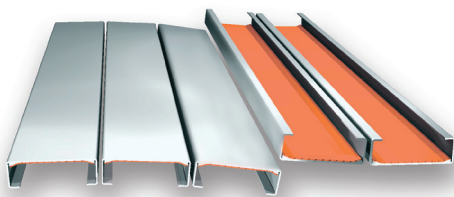

Bottom of FM 10/FM 14

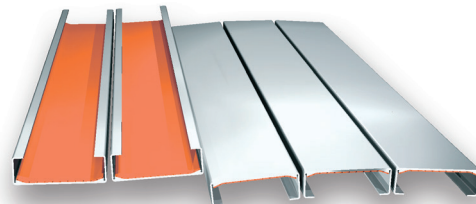

Top of FM 10/FM 14

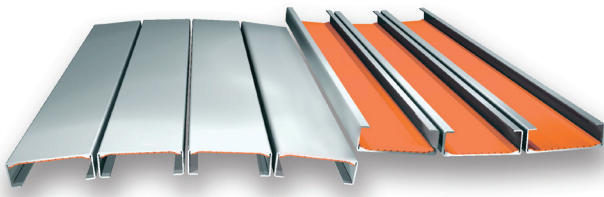

Bottom of FM 14L/FM 16

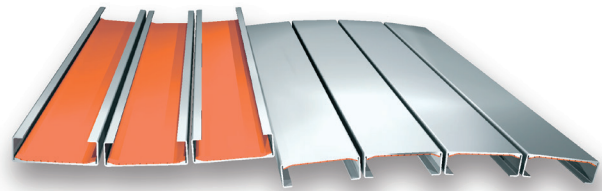

Top of FM 14L/FM 16

Heating zone 3/2 or 4/3 bottom/top

For fabrics and interlinings of outerwear, perfect results are achieved with the 3/2 or 4/3 bottom/top arrangement. The outer fabric is gently heated by the first, lower heating zone and thus processed with low shrinkage. Even voluminous outer fabrics react positively to this arrangement of heating elements.

Heating zone 2/3 or 3/4 top/bottom

The arrangement of the heating elements 2/3 or 3/4 top/bottom is the classic arrangement in the FM for the shirt and leisure sector. The adhesive of the interlining is melted by the first upper heating zone and then drawn down into the outer fabric by the longer lower heating zone.

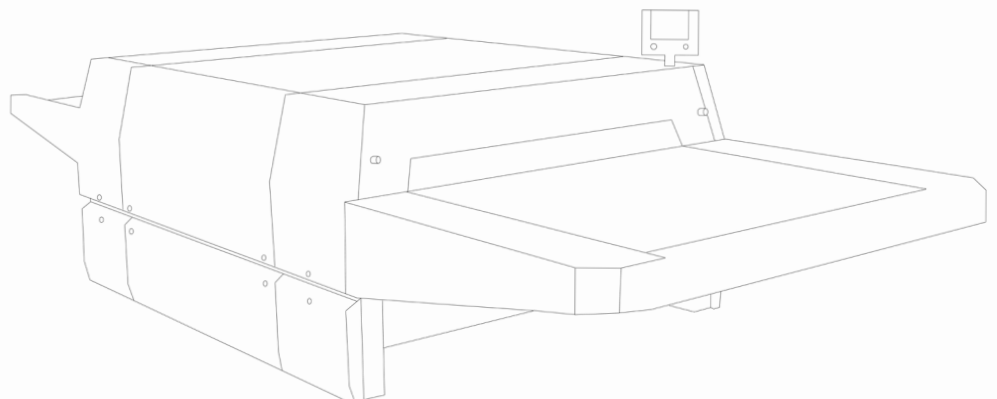

Pressure systems

The pressure system FM 10/FM 14/FM 14L/FM 16

VEIT technology also plays an innovative and leading role in sensitive printing: Through the development of patented modular printing and dual printing systems, with which the individual requirements of the user can be specifically met depending on the printing system configuration.

Standard pressure system C

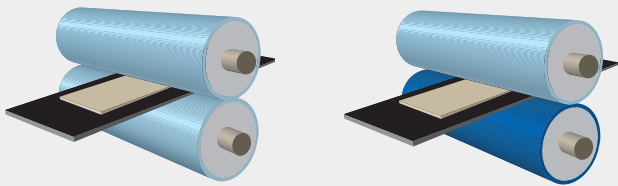

C S (soft)

Designated use: Pressure-sensitive materials in outer wear (in particular men's and ladies' wear and casual shirts)

- › Ideal combination of roller hardness for each purpose
- › Different roller combinations for outerwear and shirts

C M (medium)

Designated use: Men's wear (highly twined) and dress shirts

Double pressure system CU

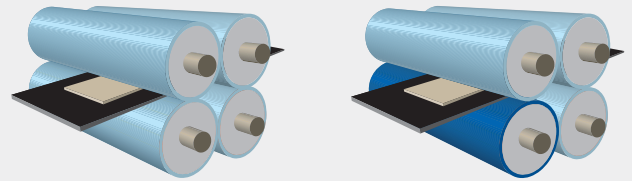

CU S (soft)

Designated use: Pressure-sensitive materials in outer wear (in particular men's and ladies' wear and casual shirts)

- › Proven performance in particular with difficult-to-fuse combinations of fabrics and interlinings
- › Universally applicable since the two pressure systems can be operated independently or in tandem
- › Both pressure systems can be adjusted individually
- › Better adhesion of thick interlinings and upper fabrics when using both pressure systems
- › All qualities can be easily processed, from very thin to very heavy interlinings

CU M (medium)

Designated use: Men's wear (highly twined) and ladies' wear and dress shirts

FUSING MACHINE FM

Design and ergonomics combined

Double pressure system CFC – FLEXO

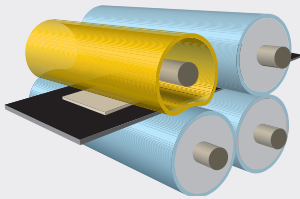

CFC:

Designated use: Pressure-sensitive and heavyweight materials which are prone to compress during fusing

- › Patented VEIT double pressure system CFC, specifically for delicate fabrics
- › Air-filled roller allows very gentle fusing thanks to even pressure distribution over the whole fusing area
- › Both pressure systems can be adjusted individually

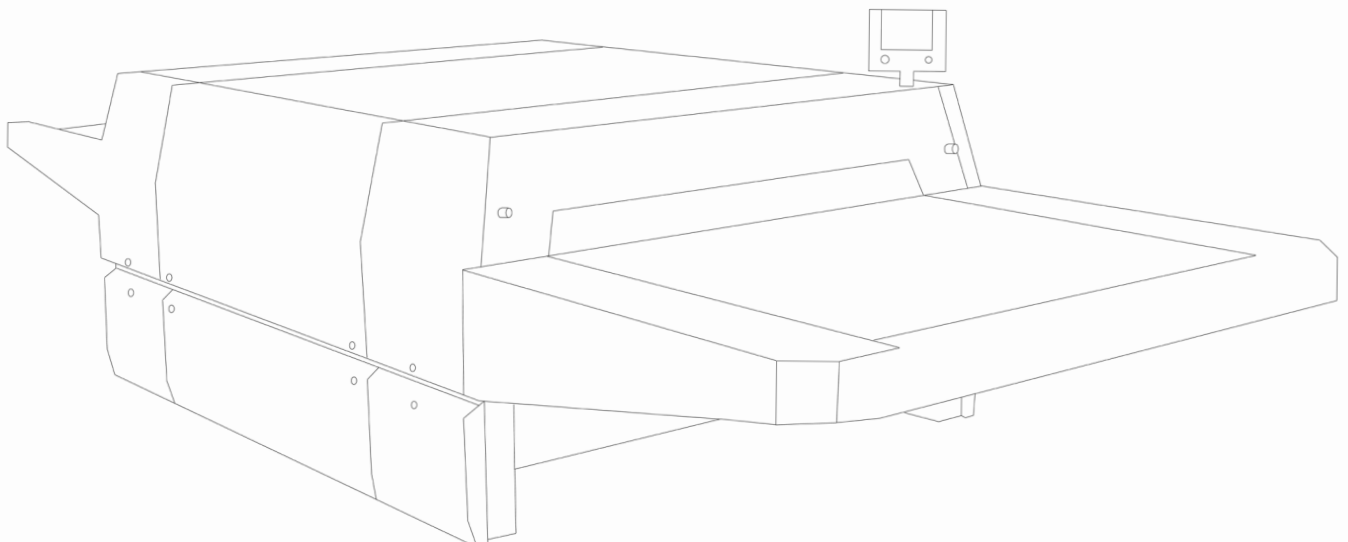

The control panel

Never before has a fusing machine been so easy to operate.

Focussing on the essential and combining it with an intuitive operation – these have been our goals in designing the new 7" colour touch screen control panel.

All the relevant fusing parameters are available at a single glance on the modern, user-friendly display. In the event of a parameter digressing from the pre-set values, say temperature is too low, the font colour turns into red and the feeding belt stops further feeding into the machine.

The integrated web server allows the VEIT Remote Service to diagnose the machine remotely.

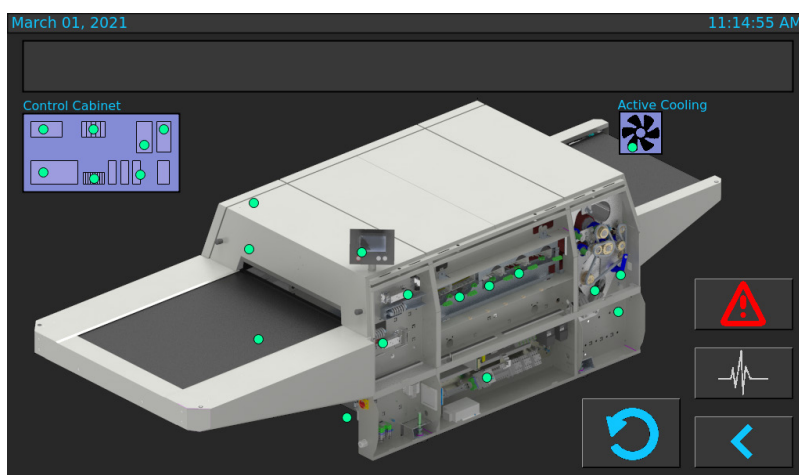

Contact pressure
of first pressure system
displayed in bar or N/cm²

Belt speed
in m/min and seconds

- > Language selection
- > USB port for printer or for making programme copies
- > Diagnostic system for the proper functioning of heating elements, compressed air supply, belt running, error log
- > Shift Management
- > Remote Service
- > Capacitive touch display
- > IO Link connection
- > Integrated OPCUA server

Stand-by function
for energy-saving during breaks

Heating
on/off

Cool-down function
for cooling the belt and
cleaning

Set temperature
of first heating zone

Actual value
of first heating zone

Actual value
of second heating zone

Set temperature
of second heating zone



Contact pressure
of second pressure
system displayed
in bar or N/cm²

Ergonomics and Visibility

Everything in view and easy to reach

In the design and construction of the FM series, particular attention was paid to further optimising the ergonomic wishes of our customers.

In addition to reducing the basic height of the machine series, the important points for the production process were made more accessible and visible.

The area of the transfer from the feeding element FE to the conveyor belt was adapted so that the materials can be better observed during the transfer. This helps to prevent misfixing.

The enlarged rear flap allows a clear view of the smoothing device and the transfer to the cooling belt, and thus an immediate visual check of the fusing results. In combination with the reduced machine width in the area of the cooling station, accessibility to the smoothing device has been made much easier.

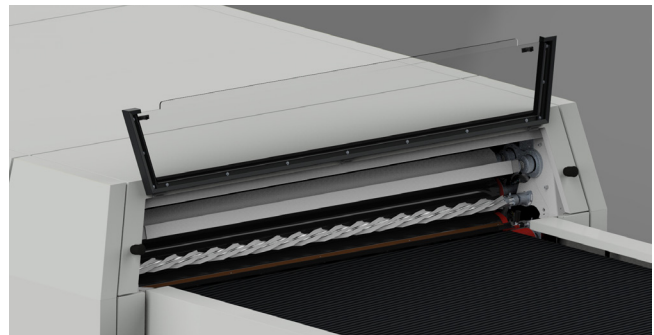
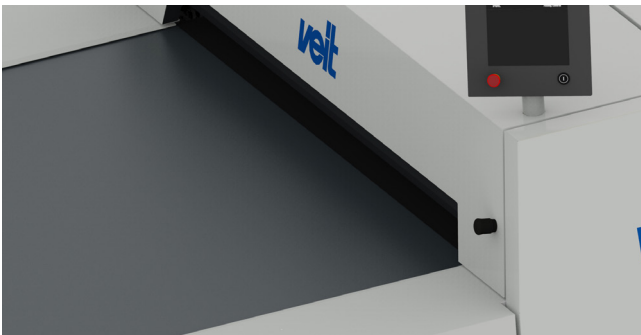

Technical Data

Continuous fusing machines							
Model	Operating width mm (inch)	Belt Speed m/min (ft/min)	Compressed air Ø=8 mm bar	Voltage Volt/Hz/kW	Dimensions: L x W x H mm (inch)	Weight kg (lb)	Consumption: compressed air l/min
FM 10 C	1000	1.0–10	6.5	3 x 400/50–60/23	4640 x 1660 x 1530 (183 x 65 x 60)	1200 (2646)	50
FM 10 CU	1000	1.0–10	6.5	3 x 400/50–60/23	4640 x 1660 x 1530 (183 x 65 x 60)	1200 (2646)	50
FM 10 CFC	1000	1.0–10	6.5	3 x 400/50–60/23	4640 x 1660 x 1530 (183 x 65 x 60)	1200 (2646)	50
FM 14 C	1400	1.0–10	6.5	3 x 400/50–60/30.5	4640 x 2060 x 1530 (183 x 81 x 60)	1430 (3153)	50
FM 14 CU	1400	1.0–10	6.5	3 x 400/50–60/30.5	4640 x 2060 x 1530 (183 x 81 x 60)	1430 (3153)	50
FM 14 CFC	1400	1.0–10	6.5	3 x 400/50–60/30.5	4640 x 2060 x 1530 (183 x 81 x 60)	1430 (3153)	50
FM 16 C	1600	1.0–10	6.5	3 x 400 / 50–60 / 48	5025 x 2260 x 1530 (198 x 89 x 60)	1600 (3527)	50
FM 16 CU	1600	1.0–10	6.5	3 x 400 / 50–60 / 48	5025 x 2260 x 1530 (198 x 89 x 60)	1600 (3527)	50
FM 16 CFC	1600	1.0–10	6.5	3 x 400 / 50–60 / 48	5025 x 2260 x 1530 (198 x 89 x 60)	1600 (3527)	50

Subject to alterations. All specifications have been made to the best of our knowledge.

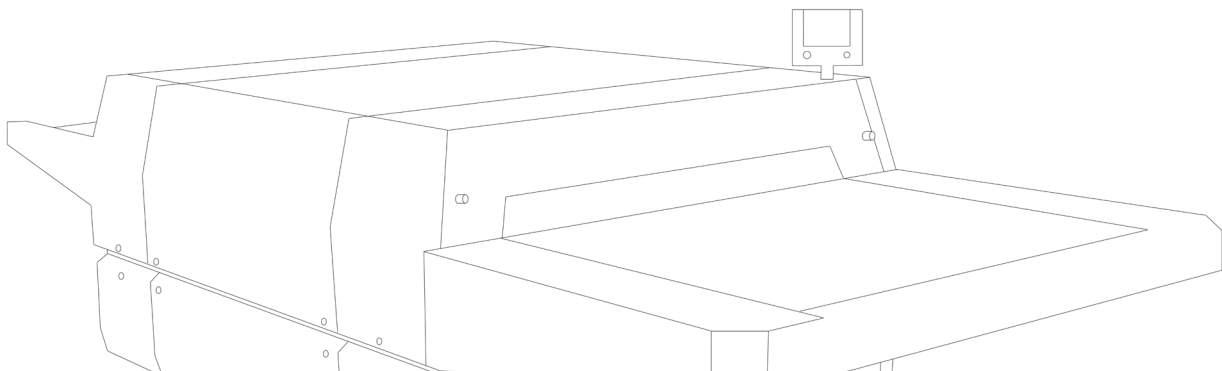

When technology meets design –
it is “Taking fusing to the next level”.

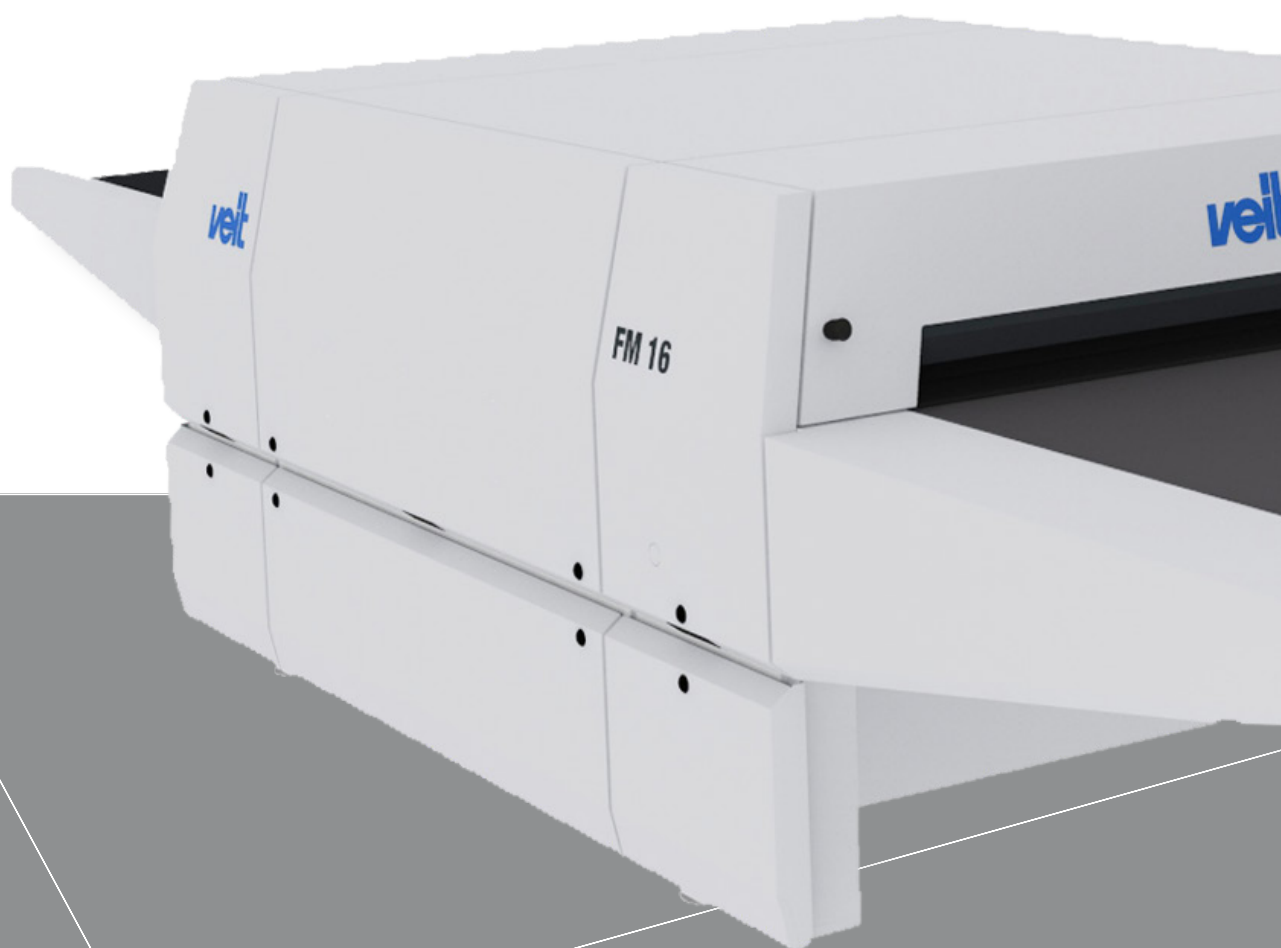



The VEIT Group



Pressing for Excellence – Why you can rely on the VEIT Group

The VEIT Group is based in Landsberg am Lech (Germany) and is the leading manufacturer worldwide for machines and plants in the field of ironing, fusing, pressing and refinishing of garments. Our product portfolio ranges from traditional ironing tables and presses to fusing machines and also includes automated units.

VEIT Group: the story of our success

- 1956 Foundation of VEIT Group with now 14 companies in 12 countries worldwide
- 1989 Purchase of BRISAY, Aschaffenburg, with a portfolio of cutting-edge ironing machines
- 2001 Acquisition of Kannegiesser GTT in Vlotho with their internationally renowned fusing machines and shirt ironing machines
- 2003 Production and further development of Kannegiesser products through VEIT
- 2014 Distribution of Kannegiesser products exclusively under the VEIT brand name
- 2020 Expansion of the main location in Landsberg with new sheet metal production and new showroom

Quality

For over 60 years, our customers' requirements and challenges have been our driving force to press for excellence. For decades, world famous brands in the German and international garment industry have placed confidence in the innovative, high quality products and services offered by the VEIT Group.

Efficiency

Our experts consult and partner with you in finding the best possible solution for your project needs, whether you require individual machines or a complete product line.

Service

Prompt delivery and professional installation of our machines and systems go hand in hand with premium training, through which we equip your staff with the skills necessary to achieve the highest possible production. Our service technicians are always available, around the world and around the clock, maximizing continuous production.



VEIT GmbH

Justus-von-Liebig-Str. 15
 86899 Landsberg am Lech
 Germany
 Tel. +49 (8191) 479-100
 Fax +49 (8191) 479-149
 E-Mail: info@veit.de
www.veit-group.com

Your local sales agent: