



Pressing for Excellence

A man in a dark suit, white shirt, and dark tie is shown from the chest down. He is standing against a background of yellow and olive green textured panels. The text 'Fusing and Shirts' is overlaid on the image in a white, sans-serif font.

Fusing and Shirts

Table of Contents

Fusing Machines

Fusing Machine Portfolio 4

VEIT Connectivity 8

Industry 4.0 9

Fusing Machine FM Series 10-18

Options for the FM Series (WR 16) 18

FuseMaster BX 600/1000 Series 19

Options for the FM and BX Series 20

Loading Systems for FM and BX Series 21

AX 450 / AX 450 C 22

Technical Data Fusing Machines 32-33

Technical Data Shirts 34-35

Shirts

Collar and Cuff Pressing

VEIT 8905 Basic 26 

Shirt Finisher / Universal Finisher

VEIT 8319 Basic 27 

VEIT SF 27 28-29

Shirt Folding Stations

VEIT FS 10 Manual Shirt Folding Station 30

VEIT FS 15 Semi-Automatic Shirt Folding Station 31 

VEIT FS 20 Semi-Automatic Shirt Folding Station
with Tuck-In Device 31

Fusing Machines



THE VEIT FUSING MACHINE PORTFOLIO

For every requirement the best solution.

AX 450 – The fully-fledged fusing machine for **shirts** and **outerwear**



AX 450

- › working width 450 mm (17.72 inch)
- › upper and lower heating zones, thermostat-controlled (**600mm - 23.62 inch**)
- › pressure system up to a maximum of 33 N/cm²
- › ideally suitable for waistband fusing, small batches, laboratories and roll-to-roll fusing
- › in-line fusing

AX 450 C

- › Working width: 450 mm (17.72 inch)
- › **NEW: pneumatic pressure system**
- › Upper and lower heating zones, thermostat-controlled (600 mm/23.62 inch long)
- › Pressure system up to 43 N/cm²
- › Ideal for in-line fusing

BX/BXT 600/1000 – The universal solution for **shirts** and **outerwear**



- › working width 600 mm or 1000 mm (23.62 inch or 39.37 inch)
- › upper and lower heating zones, individually adjustable (**length: 800mm - 31.50 inch**)
- › single or double pressure system in various degrees of hardness
- › reliable and easy to operate
- › perfectly suitable for small (600 mm - 23.62 inch) to medium-sized production plants (1000 mm - 39.37 inch)
- › gauges for electric or pneumatic failures (diagnostic system)

FM 10/FM 14 – For highest demands for shirts and outerwear



- > ideal for all shirt fabrics (FM 10) and outer fabrics (FM 10/FM 14)
- > feeding belt 1400 mm (55.12 inch), for long parts
- > separate feeding and transport belts, "cool feeding"
- > special insulation, little heat radiation
- > upper and lower heating individually controlled, with temperature limiters **(1000 mm - 39.37 inch long)**
- > separate heating zones selectable, TOP (shirt), BOTTOM (outerwear)
- > special speed-heat up function, for fast heating of the machine
- > touch screen for program storage and service functions
- > optional air and compression cooling
- > short (800 mm - 31.50 inch) or long (1400 mm - 55.12 inch) cooling belt
- > failure diagnostic system



FM 14L/FM 16/FM 18 – The most productive solution for outerwear



- Benefits as for FM 10/FM 14 plus:
- > ideally suited for coats, winter fabrics and block fusing
 - > extended heating zone, increased productivity **(length 1400 mm - 55.12 inch)**
 - > three heating zones, more gentle heating
 - > for large-scale production or centralised fusing
 - > ideal for combination with feeding systems (FE-L, ET)





F JSING MA(1)NES



velt

velt

FM 16

VEIT CONNECTIVITY

The intelligent control of the VEIT FM/LM series allows a multitude of possibilities to integrate the fusing process holistically into your production.

VEIT Connectivity offers a two-way communication tool with screen transmission and remote access to the FM/LM control.

Only you have digital access to your machine. Our VEIT service can only access your machine and support you directly if you set this manually.

Your possibilities

- › You can ensure consistent quality in your processes by recording the process parameters.
- › You can integrate the machine into your company network to be able to read out all decisive parameters such as press pressure, temperature, throughput time and the selected programme.

VEIT Remote Service

- › In the event of a malfunction, our VEIT Remote Service makes it possible for our service staff to get a first impression via an online connection.
- › In many cases, this avoids the need for a service technician on site and the associated long downtimes.

Additional applications

- › Diagnostic possibility
- › Elimination of faults
- › Support with commissioning, configuration and programming
- › Support of a technician on site

Advantages

- › Cost minimisation through increased availability, faster diagnosis and troubleshooting in the event of a malfunction
- › Digital quality assurance
- › Hotline support with our machine specialists
- › Secure connection solution



INDUSTRY 4.0

VEIT wants to make their customers' fusing operations as easy as possible by offering intelligent process solutions.

With garment production cycles becoming faster and faster, requirements for an efficient system to process materials are constantly increasing.

VEIT Fusing 4.0

“VEIT Fusing 4.0” provides a decentralised control of the fusing process in a network where the machine can communicate with other machines, the goods and itself. VEIT's FM Fusing Machine with the „VEIT Fusing 4.0“ technology is ready to meet all the requirements of intelligent manufacturing and allows its users to benefit in their production process from many of these advantages right now – even without being completely interconnected.

Process parameters

The machine itself can maintain the fusing result at a consistent level at all times by monitoring and intelligently adjusting all process parameters. Thanks to the recording of the said parameters, the manufacturer can prove the consistency of his products.

VEIT Predictive Maintenance

“VEIT Predictive Maintenance” – All VEIT machines with 4.0 technology permit the compilation of a detailed service report.

Advantages

- › Manufacturing of customised products at cost of mass production
- › Reduced energy cost („gradual warmups“)
- › Low error rate by unambiguous identification of the goods and therefore high variability at short notice and low unit cost
- › Retrieving of production data from central server and collection of data from the manufacturing environment
- › Availability of current process data plus decentralised generation of control commands (fast reaction to unplanned events)
- › Efficient, flexible process coordination
- › Accurate fine-tuning of processes through automated exchange of user-specific operational information
- › Allows quality assessment through retrospective production data analysis

FUSING MACHINE FM

Design meets ergonomics.

Optimal adjustment
of pressure system (soft, medium)
and heating sequence (top, bottom)
to the materials to be processed

Perfectly designed service concept
allows easy and regular
cleaning of machine

Visibility and accessibility

- › Improved access to smoothing device due to reduced machine width in the area of the cooling belt
- › Optimised viewing window for better visibility of the goods

Optimal fusing

thanks to exact temperature control directly at the belt



Consistent fusing quality
due to optimized cleaning of
the belts both on the
inner and the outer side.
Consequently, considerably
less contamination of roller
and fusing material

Lowest possible energy consumption
due to:

- › Separate feeding belt, no cooling of transport belt outside of machine
- › Decoupling of heating zones from machine frame
- › Enclosure of the complete machine to avoid draughts and reduce heat loss



Consistent fusing results
due to consistent pressure over the
entire operating width

Control

- › Capacitive touch display for easier operation
- › User-optimised user interface
- › Diagnostic and remote service capability
- › Rotatable and tiltable display

Functionality

- › Removable feeding element FE for uncomplicated installation in confined spaces
- › Start-stop function of the input belt in case of deviation from the set fusing parameters

Reduced wear and tear of belt
through contact-free belt control

Ergonomics

- › Weight savings on side panels for easier maintenance
- › Reduced basic machine height
- › Easy access to power supply
- › Reduced environmental temperature due to separate and cool input belt

THE HEATING CONTROL SYSTEM

Outstanding fusing results thanks to an extremely precise control of the two important fusing parameters – temperature and pressure

Modern high-tech interlinings often have only a rather small temperature range for optimal bonding with the glue. Consequently, exact temperature control today is far more important than ever before. To meet these requirements, VEIT has developed a new, innovative heating control system.

The new control element measures the temperature directly at the belt and therefore reacts extremely fast to any changes. The pre-set temperature can be maintained at a constant level and be precisely controlled. In combination with the tried-and-trusted VEIT heating units and the geometry of the heating zones, the adhesive's flow properties are perfectly set for further processing.

The Heating Element

For perfect heat radiation, stability over the entire width of the machine is essential. The heating element's aluminium construction absorbs only little energy, thus allowing best possible heat transfer to the fusing material.

Configuration of heating zones BOTTOM or TOP

Different applications require individual technical solutions. The design of the heating element when fusing outerwear parts will differ from the layout for an application in shirt fusing. Perfect adjustment of the heating zone is essential for successful fusing. VEIT's configurable heating zones are the answer to this challenge. This unique technology allows optimised adjustment of the fusing machine to the individual application.

Benefits

- › Even temperature transfer to the whole fusing area
- › Minimum loss of heat thanks to optimum heat control
- › Fast adjustment to changes in temperature with no loss of time
- › Exact temperature control without any significant deviations
- › Targeted heat transfer without loss of energy thanks to special insulation

Efficiency meets perfection.

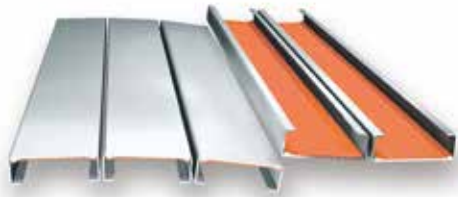

Bottom of FM 10/FM 14

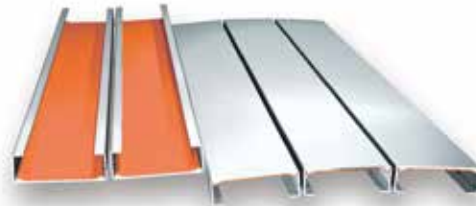

Top of FM 10/FM 14

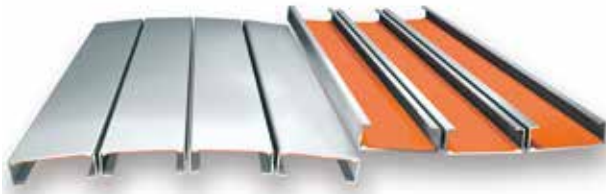

Bottom of FM 14L/FM 16/FM 18



Top of FM 14L/FM 16/FM 18

Heating zone 3/2 and 4/3 bottom/top

For fabrics and interlinings in outer wear the 3/2 and 4/3 bottom/top arrangement brings perfect results. The upper fabric is gradually warmed by the first lower heating zone, limiting shrinkage to a minimum. Heavier fabrics also react positively to this arrangement of heating elements.

Heating zone 2/3 and 3/4 top/bottom

The 2/3 and 3/4 top/bottom arrangement of heating elements is the standard layout at the FM for shirts and sportswear. The initial upper heating zone melts the adhesive to the interlining. The extended lower heating zone then draws it downwards into the upper fabric.

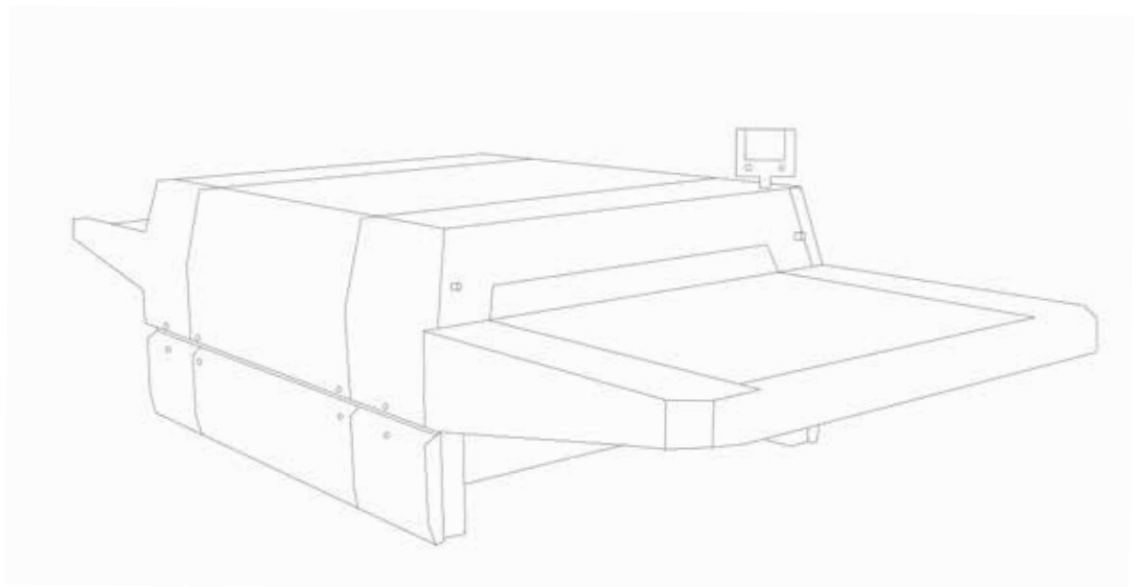

PRESSURE SYSTEMS

The FM 10/FM 14/FM 14L/FM 16/FM 18 pressure system

VEIT technology plays a leading innovative role in sensitive pressure systems:
 We have developed and patented modular pressure and double pressure systems that exactly meet the user's individual requirements thanks to special configurations.

Standard pressure system C

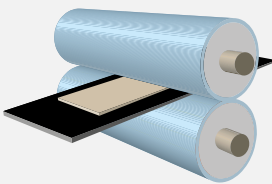

C S (soft)

Designated use: Pressure-sensitive materials in outer wear (in particular men's and ladies' wear and casual shirts)

- › Ideal combination of roller hardness for each purpose
- › Different roller combinations for outerwear and shirts

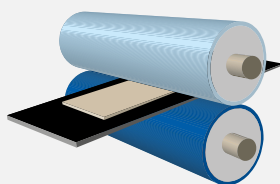

C M (medium)

Designated use: Men's wear (highly twined) and dress shirts

Double pressure system CU

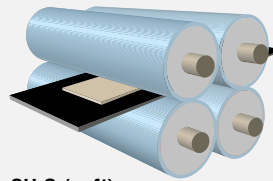

CU S (soft)

Designated use: Pressure-sensitive materials in outer wear (in particular men's and ladies' wear and casual shirts)

- › Proven performance in particular with difficult-to-fuse combinations of fabrics and interlinings
- › Universally applicable since the two pressure systems can be operated independently or in tandem
- › Both pressure systems can be adjusted individually
- › Better adhesion of thick interlinings and upper fabrics when using both pressure systems
- › All qualities can be easily processed, from very thin to very heavy interlinings

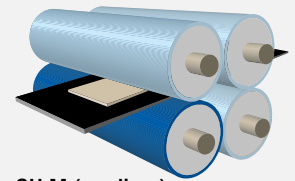

CU M (medium)

Designated use: Men's wear (highly twined) and ladies' wear and dress shirts

Double pressure system CFC – FLEXO

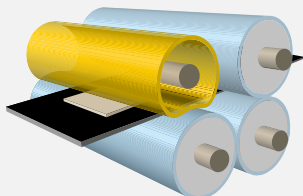

CFC

Designated use: Pressure-sensitive and heavyweight materials which are prone to compress during fusing

- › Patented VEIT double pressure system CFC, specifically for delicate fabrics
- › Air-filled roller allows very gentle fusing thanks to even pressure distribution over the whole fusing area
- › Both pressure systems can be adjusted individually

THE CONTROL PANEL

Never before has a fusing machine been so easy to operate

Focussing on the essential and combining it with an intuitive operation – these have been our goals in designing the new 7" colour touch screen control panel.

All the relevant fusing parameters are available at a single glance on the modern, user-friendly display. In the event of a parameter digressing from the pre-set values, say

temperature is too low, the font colour turns into red and the feeding belt stops further feeding into the machine.

In addition, fusing programs can be created and saved in the control panel. They can then be copied to other FM machines via USB port.



- > Language selection
- > USB port for making program copies
- > Diagnostic system for the proper functioning of heating elements, compressed air supply, belt running, error log

Set temperature of first heating zone

Actual value of first heating zone

Contact pressure of first pressure system displayed in bar or N/cm²

Belt speed in m/min and seconds

Stand-by function for energy-saving during breaks

Heating on/off

Cool-down function for cooling the belt and cleaning

Actual value of second heating zone

Set temperature of second heating zone



Contact pressure of second pressure system displayed in bar or N/cm²

FUSING MACHINES

FUSING MACHINES

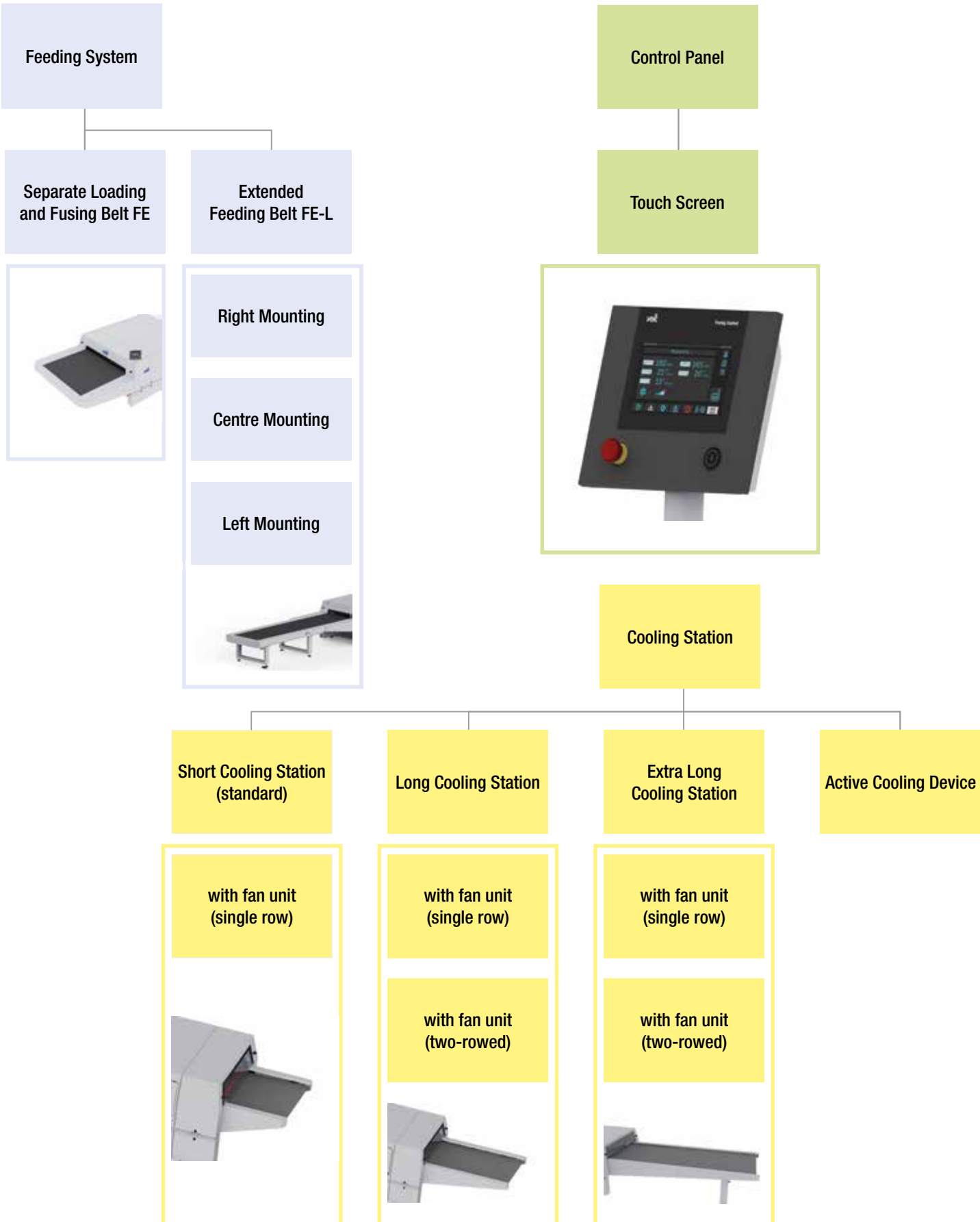

FM 10 / FM 14 / FM 14L / FM 16 / FM 18

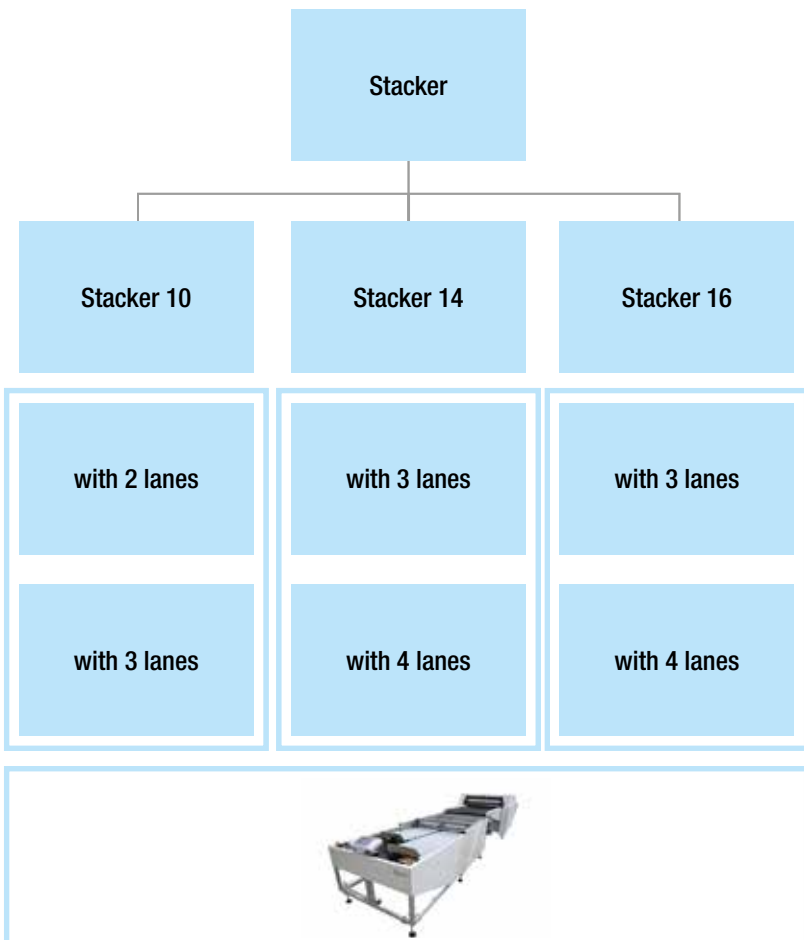
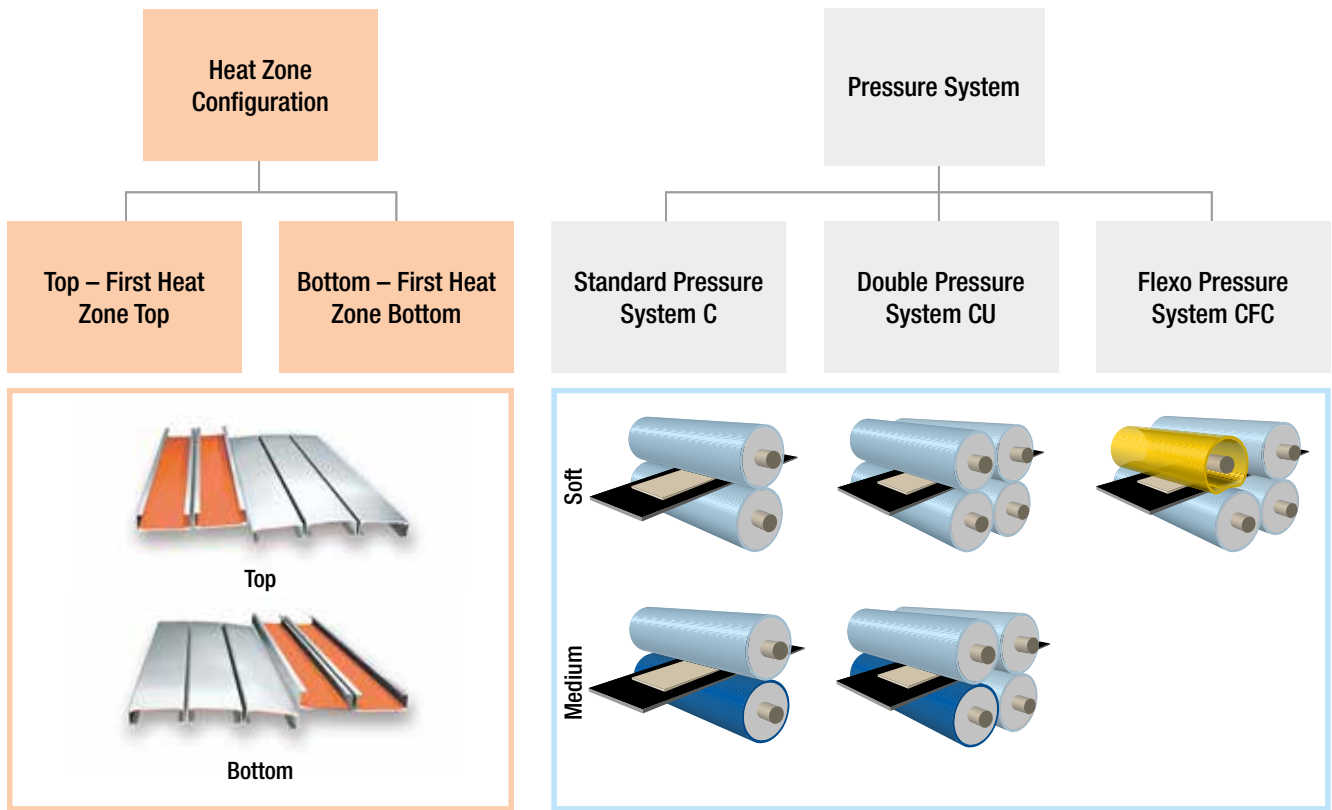

ERGONOMICS AND VISIBILITY

Everything in view and easy to reach

In the design and construction of the FM/LM series, particular attention was paid to further optimising the ergonomic wishes of our customers.

In addition to reducing the basic height of the machine series, the important points for the production process were made more accessible and visible.

The area of the transfer from the feeding element FE to the conveyor belt was adapted so that the materials can be better observed during the transfer. This helps to prevent misfixing.

The enlarged rear flap allows a clear view of the smoothing device and the transfer to the cooling belt, and thus an immediate visual check of the fusing results. In combination with the reduced machine width in the area of the cooling station, accessibility to the smoothing device has been made much easier.

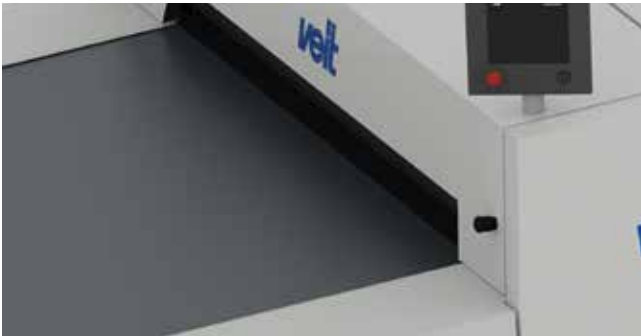

Options for the FM Series

Winding and rewinding device WR 16

The winding and rewinding device is the perfect addition to your VEIT laminating or fusing machine. A fully automatic process of unwinding individual rolls, then rewinding into a single roll after the laminating or fusing process.

Advantages:

- › Perimeter controlled technology for tension-free material handling and easy roll change
- › Smooth and precise electrical motor control of all machine movements
- › The control panel provides easy operation of the process sequence and speed control
- › Complete process of fusing / laminating / pre-shrinking
- › Optical web edge detection
- › Integrated cutting device
- › Roll width up to 1600 mm
- › Various versions:
 - 2 to 1
 - 3 to 1

FuseMaster BX/BXT 600, BX/BXT 1000 Serie



The compact solution!

Designed for daily use in outerwear or dress shirt productions. This sturdy and reliable machine is the optimal solution in both cases.

Advantages:

- > Sturdy, compact design requires minimal floor space
- > Extended heat chamber
- > Rapid machine warm-up
- > Totally reliable and adjustable/maintains accurate temperature and pressure

The Control Unit:

Control of the fusing parameters is of utmost importance in a fusing machine, where all important details can be overseen in a clear and readable manner. Fluctuations in temperature are highlighted to draw quick attention.



Advantages:

- > Separately controlled and adjusted upper and lower heat zones, individually adjustable for various fabric and interlining combinations
- > Clear, simple color display with temperature control to prevent too low or too high temperatures
- > Diagnostic system for belt progression, electrical supply and compressed air supply



The Heating System:

As with all continuous VEIT fusing machines, our special heating elements play an important role. Clearly defined heat zones provide for optimal fusing results.

Advantages:

- > Uniform surface temperature due to curved heat zone
- > No gaps between heating elements, facilitating uniform heat distribution
- > Rapid temperature change
- > Specially insulated heating elements for minimal energy waste

The Pressure System:

The precise pressure for successful fusing of different interlinings and fabrics varies; therefore, a pressure system must be able to address these needs. The BX is the only fusing machine in its class offering a choice of two standard pressure systems to best meet the needs of our clients.

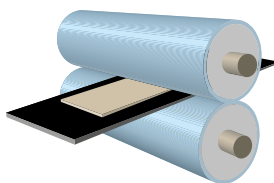

C S (soft)

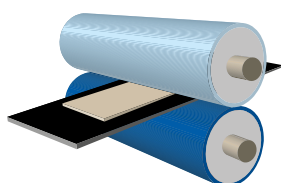

C M (medium)

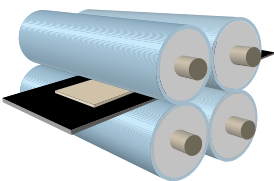

CU S (soft)

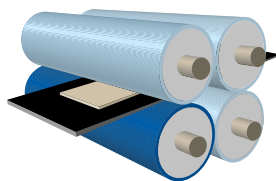

CU M (medium)

BX 600/1000 S (soft)

Applicable for pressure sensitive fabrics used in sportswear and especially in women's and men's apparel

BX 600/1000 M (medium)

Applicable for common fusing applications in goods with high-twist yarns and dress shirt industry

Advantages:

- > Roller combinations can be chosen between soft and medium
- > Fast exchange of pressure rollers possible at any time

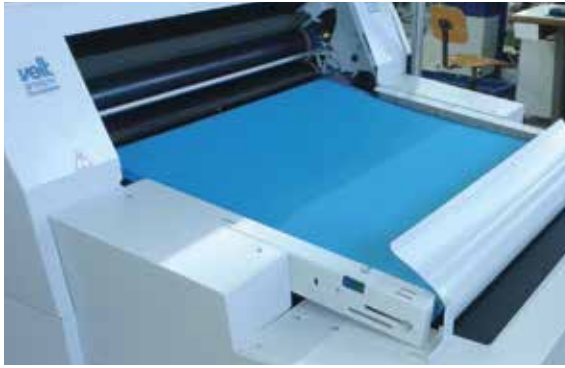

Options for the FM and BX Series

Return-to-Operator System (for BX)

A return-to-operator system is especially beneficial for smaller production runs, allowing a single operator to both load and unload the machine.

Advantages:

- > Ideal for minimal work space
- > Accommodates two independent operators



7" colour touch display (for BXT 600/1000)

All the relevant fusing parameters are available at single glance on the modern, user-friendly display.

Advantage:

- > Easy operating with new 7" colour touch display



Rotating Strip-Off Device (for FM)

Through rotation of strip-off device along the upper belt, pieces adhering to the belt are gently and effectively removed.

Advantages:

- > Gentle removal of pieces from the upper belt with rubber ridges
- > Unique design allows damaged ridges to be replaced individually without removal of the entire strip-off device, facilitating rapid and cost effective repair
- > Low maintenance



Lateral Loading Tables (for FM)

For preparation of oversized pieces, the fusing machine can be equipped with lateral loading tables.

Loading Systems for FM and BX

A loading system may be incorporated for even more efficient use of the fusing machine.



FE-L Loading System

The **VEIT FE-L** is an extended version of the FE loading belts in the FM and BX series. The **FE-L** can either be added to extend the standard FE loading belts or can be installed instead of the standard FE loading belts. An extended loading zone allows for additional operators.

Advantages:

- › Foot switch can be used to start and stop the belt
- › Oversized pieces can be processed
- › Additional operators can be utilized for loading
- › FE-L can be installed on the FM
- › As an additional installation – 4400 mm (176 inch)
- › As the primary installation – 3000 mm (120 inch)

ET Timed Loading Belt

The **ET timed loading belt** is an additional function of the FE. As an accessory to the assembly belt, a timed belt acts as a buffer between the rapid speed of the loading belt and the slower moving feeding belt.

Advantages:

- › Choice of cycles including timed, continuous or coupled lanes
- › Pieces positioned precisely on a motionless belt
- › Independent functioning of adjacent belts
- › Automatic speed adjustment of the timing belt

Stacker

It is important that fused assemblies be handled gently to allow them to cool prior to further processing.

The **Stacker** guides the fused assemblies from the loading system's cooling belt of the BX or FM series to the unloading table. At this point the unloading table is activated by a sensor and moves under the piece until the entire length is transferred. Thereafter, the unloading table returns to its position under the belt to receive the next piece. This system is available for working widths 1000, 1400 and 1600, from two to four separate operating trays.



Advantages:

- › Automatic stacking of fused assemblies
- › Choice of various belt widths
- › Coupling of stacker lanes for extra wide pieces
- › Flat transfer of fused assemblies
- › Pieces placed in order
- › Pieces placed for precise bundling

AX 450 / AX 450 C



Despite its minimized dimensions, the **AX 450** offers the same attributes as the larger models. It can be utilized for fusing waistbands as well as full-fledged fusing of sportswear and dress shirts.

Advantages:

- > Full-fledged fusing for small production runs, labs or assembly lines
- > Requires no compressed air
- > Single phase electrical connection
- > Rolling stand design
- > Partial fusing capabilities



The Control Unit:

Even our compact fusing machine comes equipped with a full-fledged control unit.

Advantages:

- > Unique in its class, a diagnostic system for heating elements, motor control and belt control
- > Clear, simple color display for under or over heating
- > Calibrated thermostat, necessary for belt exchange or different belt types
- > Set/actual temperature monitoring

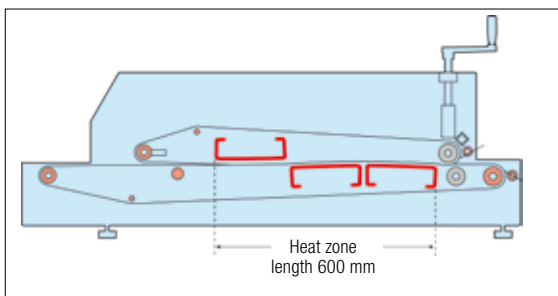

- Heating System
- Pressure System

The Heating System:

The heat technology and heat zone configurations are incorporated from our larger fusing machines, guaranteeing maximum quality.

Advantages:

- > Separate upper and lower heat zones
- > Proven VEIT surface heat technology with uniform surface distribution
- > Minimal energy usage, with each outlet serviced by 16 amp fuse
- > Panel heating elements provide specific heat transfer with minimal energy waste

AX 450 / AX 450 C

The mechanical Pressure System:

The **AX 450** has a sophisticated mechanical pressure system which operates without compressed air and yet delivers precise pressure. Pressure specifications are shown in N/cm², as requested by leading interfacing suppliers.

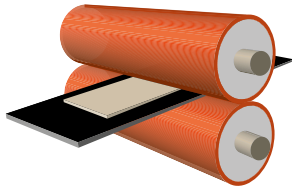

The pneumatic Pressure System

With the trend towards increasing individualisation, producing **small numbers** is becoming increasingly important **in shirt production**. Customised production of tailor-made shirts, too, results in a need for flexible production lines. With this fully-fl edged fusing machine, VEIT FUSING provides the possibility of decentralised fusing directly in the production line without any cut-backs in quality.

Options:

Unloading Slide

Accommodates large and small fused assemblies for cooling.



Waistband Fusing Device

Various options are available for mechanical unwinding and rewinding for waistband fusing. The waistband fusing device may be operated individually or by two people. We further recommend a loading guide for accurate positioning of the face fabric and the interlining.



Mechanized Rewinding "Stretch"

We offer an electronically driven option for rewinding fused waistbands of elastic fabrics, eliminating stretch.

Shirts



OVERVIEW

For every requirement the best solution.

8905 Collar and Cuff Press – Pressing of Collar and Cuffs



8319 Universal Finisher – Finishing the complete shirt



SF 27 Shirt Finisher – Finishing the complete shirt



Shirt Folding Stations – Folding of shirts





VEIT 8905

Pressing of collar and cuffs

- › Electrically heated buck shapes
- › Also available as steam heated version
- › Suitable for pre-washed or moisturized shirts
- › Control unit for temperature and pressing time
- › Specially shaped upper buck made of polished stainless steel
- › **Integrated vacuum-function**
- › **Central, even pressure supply**



Universal Finisher VEIT 8319/VEIT 8319 E

Finishing the complete shirt

The big advantage of this machine is its **universal usability**. It is made **for shirts and blouses** but can also be used for finishing **sports jackets and coats**.

The pneumatic sleeve tensioners for **short and long sleeve shirts** finish the sleeves without marks. The **powerful hot air fan** provides enough power to finish shirts very efficiently with good quality. With the **exchangeable lapel clamps** the finisher can be adapted to your individual needs.

On demand also available as electrically heated version **VEIT 8319 E Basic**.

Advantages:

- > Optimal forming due to 3-D movable tensioning elements
- > Automatic adjustment of width from XS to XXXL
- > Belt drive for a smooth and gentle movement of the hem clamp
- > Integrated re-stretching function prevents wrinkles



Side vent fixing

The **automatic side vent fixing device** is not only used on side vents, but is generally used for holding the shirt or smock seams.



Automatic height adjustment

Exact height adjustment of the tensioning unit by Belt-Drive-System controlled by photocell.



The control unit

The control unit is clearly arranged and easy to handle for controlling the individual finishing steps. The hand finisher for touch up is positioned to allow fast ergonomic access.



**80 perfect shirts per hour
with only 20 kg/h steam consumption!**

VEIT SF 27 Shirt Finisher

Finishing the complete shirt

Maximum energy-saving - astounding performance

The development of the new SF 27 Shirt Finisher was carried out with the involvement of fluidic engineers and specialists in the field of emission optimization. With the new model, VEIT has succeeded in further improving both the quality of the finished shirt and the functionality and ergonomics of the Shirt Finisher. Emission values such as energy consumption, noise and heat generation have been significantly reduced.

Unique benefits:

- › High quality finish without touch-up
- › 3 dimensional adjustable sleeve tensioners for the perfect result
- › Heat/energy recovery* gives additional cost savings and faster payback
- › Moisture control* for shortest drying times
- › Minimal heat and noise emissions provide a pleasant working environment
- › Small insertion dimension, fits through any standard door
- › Standby mode* to save energy when the machine is not in use
- › Unique toothed belt drive for size retention even with stretch materials

Energy efficiency

- › Optimised heat recovery through new extraction concept
- › Optimised air and steam flow for maximum steam savings
- › Fast and energy-efficient drying of the button-facing due to optimised airflow. As a result no heated front clamp is necessary.

Technical highlights

- › Optimised tensioning system
- › Same footprint with or without heat recovery system
- › Reduced noise
- › Industry 4.0 standard - enables monitoring of current production

User-friendliness

- › Simple process flow
- › Short training period for new employees
- › Optimised ergonomics



Hem clamp unit

The hem clamp unit and the sidevent clamps are particularly permeable to air for fast drying of the side seams and crease-free fixation of the shirt hem.



Touch screen control unit

A clearly arranged touch screen panel shows all the important functions at a glance. The easily understandable symbols make the operation very simple. An integrated counter provides information about the output.



**Unique moisture control:
The process ends
when the shirt is dry.**

VEIT SF 27 Shirt Finisher

Flexible Bust

- › Bust SL – perimeter 780-940 mm (30,7 – 37,0 inch)

The shoulder width is adjustable for bust SL between 43 and 54 cm (16.9 – 21.3 inch).

The hem circumference is:

- › SL: 90 – 170 cm (35.4 – 66.9 inch)

For bust SL, an **automatic unloading station** is optionally available to shorten cycle times and increase productivity.

Optimised Heat Recovery System* due to new extraction concept

The heat recovery system is equipped with the latest heat exchange technology. The technical components have been additionally integrated into the unit.

The optimized energy recovery system reduces your ecological footprint. Fast, economical drying times and a high-quality finishing result with the lowest energy consumption are our claim.

The optionally available heat recovery system absorbs the radiated heating energy and dries the humid air with the help of a heat exchanger.

This also allows the humid exhaust air to be discharged to the outside.

Your benefits:

- › Considerable energy savings of up to 44 per cent
- › Increased drying performance – shorter process cycle times
- › Less heat radiated to the surroundings
- › Pleasant room climate thanks to the reduced humidity
- › Lowers room temperature by up to 4°C

Moisture Control*

The moisture control unit shortens cycle times and saves energy. The unit is unique on the market.

During the drying process, it permanently measures the residual moisture in the shirt and the shirt's dryness in the front placket. As soon as the shirt is dry, it automatically switches off the blowing. No operator intervention is required for exact and fast drying of the shirt.

* optional

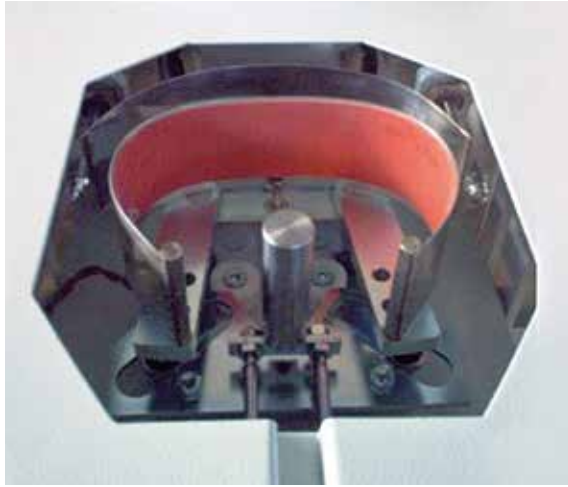

Shirt Folding Stations with automatic Collar Former

Maximum flexibility allows folding men's, ladies' and children's shirts in various styles, qualities and fabrics. The height-adjustable folding station with its adjustable accessories, shelves and left or right operation provides for an **ergonomic working place**. Special width of the table top and a button groove permit easy handling and an **efficient placement** of the shirt. The **folding template can be easily shifted or adjusted** (depends on unit model) for different folding sizes.

VEIT Shirt Folding Tables are all equipped with the special Universal Seamless Collar Former.

- > Automatically adjusting to a **wide range** of shirt collar sizes
- > Made in one single piece, it shapes and gives the final form with uniform pressure and heat **avoiding marks and without damage to shirt label** as it is free from heat
- > A special long metallic band guarantees perfect finishing of the external part of the collar
- > Electrically heated; temperature can be set adequately to the fabric on a digital controller
- > Adjustment of collar shape easily possible: round oval, long oval, wide oval



VEIT FS 10 Manual Shirt Folding Station

Folding of shirts

- > Automatic **universal collar former**
- > Manual operation for the up and down folding template
- > Template according to the required folding sizes
- > Temperature controller with five level settings
- > Function by standard pedal



VEIT FS 15 Semi-Automatic Shirt Folding Station

Folding of shirts

- > Automatic **universal collar former**
- > Automatic up and down movement of folding template in three steps **for an easy folding procedure** and **easy unloading of the shirt without damage to the collar shape**
- > Template according to the required folding sizes
- > Digital temperature control
- > Pedal sequencer
- > **Piece counter**
- > **Cycle select** for polo shirts



Needle free!



VEIT FS 20 Semi-Automatic Shirt Folding Station with Tuck-In Device

Folding of shirts

- > Automatic **universal collar former**
- > Automatic up and down movement of folding template in three steps **for an easy folding procedure and easy unloading of the shirt without damage to the collar shape**
- > Easily **adjustable template** for different folding sizes, no storage of different plates necessary
- > **Tuck-In Device**: to tuck in the shirt's tail into the shirt at the end of the folding process to avoid pins or clips. This function can be turned off when not required
- > **Shoulder system**: to block the shirt shoulders in correct position during the folding process
- > Digital temperature control
- > Pedal sequencer
- > **Piece counter**
- > **Special cycle** for polo shirts

Adjustable folding sizes:

Length from 310 mm to 385 mm/12.2 up to 15.2 inch
Width from 205 mm up to 300 mm/8.1 to 11.8 inch

Fusing Machines

Continuous fusing machines							
Model	Fusing width in mm (inches)	Belt Speed in m/min (ft/min)	Compressed air ($\varnothing = 8$ mm) in bar	Electric Voltage in Volt / Hz / kW	Dimensions: L x W x H in mm (inches)	Weight in kg (lb)	Consumption: Compressed air in l/min
FM 10 C FM 10 CU FM 10 CFC	1000 (40)	1.0–12.0 (3.3–39)	6.5	3 x 400/50–60/23	4845 x 1650 x 1510 (191 x 65 x 60) ⁵⁾ 5650 x 1650 x 1510 (222 x 65 x 60) ⁶⁾	1200 (2646)	50
FM 14 C FM 14 CU FM 14 CFC	1400 (55.11)	1.0–12.0 (3.3–39)	6.5	3 x 400/50–60/29,5	4845 x 2050 x 1510 (191 x 81 x 60) ⁵⁾ 5650 x 2050 x 1510 (222 x 81 x 60) ⁶⁾	1430 (3153)	50
FM 14L C FM 14L CU FM 14L CFC	1400 (55.11)	1.0–12.0 (3.3–39)	6.5	3 x 400/50–60/42	5245 x 2050 x 1510 (206 x 81 x 60) ⁵⁾ 6050 x 2050 x 1510 (238 x 81 x 60) ⁶⁾	1500 (3307)	50
FM 16 C FM 16 CU FM 16 CFC	1600 (63)	1.0–12.0 (3.3–39)	6.5	3 x 400/50–60/48	5245 x 2250 x 1510 (206 x 89 x 60) ⁵⁾ 6050 x 2250 x 1510 (238 x 89 x 60) ⁶⁾	1600 (3527)	50
BX/BXT 600 C BX/BXT 600 CU	600 (24)	1.7–10 (5.5–34)	6.5	3 x 400/50–60/10.8	2900 x 1150 x 1500 (114 x 46 x 60)	520 (1144)	< 1
BX 1000 C BX 1000 CU BXT 1000 FE C/CU	1000 (40)	1.7–10 (5.5–34)	6.5	3 x 400/50–60/17.5	3600 x 1580 x 1500 (144 x 62 x 60)	670 (1474)	< 1
AX 450	450 (18)	1.6–10 (5.4–34)	mechanical	1 x 230/50–60/3.6	2050 (82) ²⁾ x 930 (37) ³⁾ x 604/1302 (24/52) ⁴⁾	330/370 (728/816) ¹⁾	–
AX 450 C	450 (18)	1.6–10 (5.4–34)	pneumatical	1 x 230/50–60/3.6	2050 (82) ²⁾ x 930 (37) ³⁾ x 604/1302 (24/52) ⁴⁾	330/370 (728/816) ¹⁾	< 1

AX 450: ¹⁾ with base frame/ ²⁾ without loading guide/ ³⁾ with entry table/ ⁴⁾ with and without base frame

⁵⁾ FM with short cooling station / ⁶⁾ FM with long cooling station

Fusing Machines

Pressure Values for Fusing machines		
Model and pressure system	pressure in bar	pressure in N/cm ²
AX 450	mechanical	0–33 N/cm ²
AX 450 C	mechanical	0–43 N/cm ²
BX 600 Soft	1–6	2–44 N/cm ²
BX 600 Medium	1–6	4–49 N/cm ²
BX 1000 Soft	1–6	2–44 N/cm ²
BX 1000 Medium	1–6	4–49 N/cm ²

Options								
Model	Working Width in mm (inches)	Loading Length in mm (inches)	Air Pressure 6 bar Ø = 8 mm	Electric Voltage in Volt / Hz / kW	Dimensions: L x W x H in mm (inches)	Weight in kg (lb)	Air Consumption in l/min	Lanes
FE-L	950 (38)	3000 (120)	–	1 × 230/50–60/0.55	3130 × 1110 × 850–950 (125 × 44 × 30–38)	250 (550)	–	1
ET 4.5 / 14	450 (18)	1400 (56)	–	3 × 400/50–60/2	3130 × 1200 × 980 (125 × 48 × 39)	300 (660)	–	2
Stacker 10	1000 (40)	–	4	3 × 400/50–60/1.4/ 3 × 230/50–60/1.4	3260 × 1430 × 830–845 (130 × 57 × 33–34)	820 (1804)	45	–
Stacker 14	1400 (56)	–	4	3 × 400/50–60/1.4/ 3 × 230/50–60/1.4	3260 × 1855 × 830–845 (130 × 74 × 33–34)	920 (2024)	45	–
Stacker 16	1600 (64)	–	4	3 × 400/50–60/1.4/ 3 × 230/50–60/1.4	3260 × 2030 × 830–845 (130 × 81 × 33–34)	1050 (2310)	45	–
WR 16	1600 (64)	–	–	230 V / 50-60 Hz	Winding device: 2360 x 2659 x 1565 (93 x 105 x 62) Rewinding device: 700 x 2385 x 1045 (27.5 x 94 x 41)	885 (1951)	–	–

* Subject to alterations. All specifications have been made to the best of our knowledge, Special voltage upon request. Pictures can include optional equipment. All standard measurements are approximate.

Shirts

Model	Page	Length in mm (inches)	Width in mm (inches)	Height in mm (inches)	Weight in kg (lbs)
Shirt finishers and presses					
VEIT 8905 Collar and Cuff Press	26	1100 (43.3)	850 (33.5)	1790 (70.5)–1890 (74.4)	190 (418.9)
VEIT 8319 Universal Finisher	27	1470 (57.9)	2220 (87.4) ³⁾ / 890 (35.0) ⁴⁾	1720 (67.7)	195 (433)
VEIT 8319 Universal Finisher E	27	1470 (57.9)	2220 (87.4) ³⁾ / 890 (35.0) ³⁾	1720 (67.7)	195 (433)
VEIT SF 27 Shirt Finisher	28	1380 / 1820 (54.3 / 71.7)	2370 ³⁾ /1464 ⁴⁾ (93.3 ³⁾ /57.6 ⁴⁾	1790 (70.5)	340 (750)
VEIT SF 27 Shirt Finisher with heat recovery system	28	1510 / 1910 (59.4 / 75.2)	2370 ³⁾ /1464 ⁴⁾ (93.3 ³⁾ /57.6 ⁴⁾	2646 (104)	430 (948)

Shirt folding tables

VEIT FS 10 Manual Shirt Folding Station	30	1350 (53.1)	650 (24.6)	880 (34.6)–1080 (42.5) ¹⁾ 1360 (53.5) ²⁾	80 (176)
VEIT FS 15 Semi-Automatic Shirt Folding Station	31	1350 (53.1)	650 (24.6)	880 (34.6)–1080 (42.5) ¹⁾ 1360 (53.5) ²⁾	80 (176)
VEIT FS 20 Semi-Automatic Shirt Folding Station	31	1600 (63.0)	900 (35.4)	880 (34.6)–1080 (42.5) ¹⁾ 1500 (59.1) ²⁾	85 (187)

1) working height

2) total height

3) Sleeve tensioners out

4) Sleeve tensioners in

Shirts

Model	Steam Consumption in kg/h (lbs/h)	Working Air Pressure in bar (lbs)	Steam operating pressure (bar)	Air Consumption in l/min (cub.ft/min)	Connected Load Volt/Hz/kW	Productivity approx. pieces/h
Shirt finishers and presses						
VEIT 8905 Collar and Cuff Press Basic	8–10 (17–22) ¹⁾ –	6 (87)	4.5–6	63 (1.3)	1 × 230/50–60/0.9 ¹⁾ 3 × 400/50–60/3.3 ²⁾	90
VEIT 8319 Universal Finisher	35 (145.5) ³⁾	6 (87)	6.0	3 (0.1)	3 × 400/50–60/2.6 3 × 220/50–60/2.8	35
VEIT 8319 Universal Finisher E	–	6 (87)	6.0	3 (0.1)	3 × 400/50–60/17	35
VEIT SF 27 Shirt Finisher	20 ³⁾	6 (87)	6.0	11	400/50–60/2.1	40 (10 % moisture) 80 (dry)
VEIT SF 27 Shirt Finisher with heat recovery system	14 ³⁾	6 (87)	6.0	11	400/50–60/3.2	40 (10 % moisture) 80 (dry)

Shirt folding tables

VEIT FS 10 Manual Shirt Folding Station	–	5–6 (80–87)	–	1 (0.04)	1 × 200–240/50–60/0.1	60
VEIT FS 15 Semi-Automatic Shirt Folding Station	–	5–6 (80–87)	–	1 (0.04)	1 × 200–240/50–60/0.1	70
VEIT FS 20 Semi-Automatic Shirt Folding Station	–	5–6 (80–87)	–	1 (0.04)	1 × 110–230/50/0.1	85

1) Steam heated

2) Electrically heated

3) Steam consumption depending on preset parameters

The VEIT Group



Pressing for Excellence – Why you can rely on the VEIT Group

The VEIT Group is based in Landsberg am Lech (Germany) and is the leading manufacturer worldwide for machines and plants in the field of ironing, fusing, pressing and refinishing of garments. Our product portfolio ranges from traditional ironing tables and presses to fusing machines and also includes automated units.

VEIT Group: the story of our success

- 1956 Foundation of VEIT Group with now 14 companies in 12 countries worldwide
- 1989 Purchase of BRISAY, Aschaffenburg, with a portfolio of cutting-edge ironing machines
- 2001 Acquisition of Kannegiesser GTT in Vlotho with their internationally renowned fusing machines and shirt ironing machines
- 2003 Production and further development of Kannegiesser products through VEIT
- as of 2014 Distribution of Kannegiesser products exclusively under the VEIT brand name

Quality

For 70 years, our customers' requirements and challenges have been our driving force to press for excellence. For decades, world famous brands in the German and international garment industry have placed confidence in the innovative, high quality products and services offered by the VEIT Group.

Efficiency

Our experts consult and partner with you in finding the best possible solution for your project needs, whether you require individual machines or a complete product line.

Service

Prompt delivery and professional installation of our machines and systems go hand in hand with premium training, through which we equip your staff with the skills necessary to achieve the highest possible production.



VEIT GmbH

Justus-von-Liebig-Str. 15
 86899 Landsberg am Lech
 Germany
 Tel. +49 (8191) 479-100
 E-Mail: info@veit.de
www.veit-group.com

Your local sales agent:

